

Z1225 PLATE TYPE SYSTEM – WATER COOLERS



ENGINEERING SPECIFICATION

Zurn Z1225 water cooler support system with top and bottom plates comes complete with Dura-Coated rectangular steel uprights with welded feet, adjustable support plates, and mounting fasteners.

NOTES

Dimensional data for letter dimensions depends on fixture type and manufacturer. See Zurn Carrier/Fixture Rough-In information at www.zurn.com for specific rough-in dimensions.

Product Number	Approximate Weight lb [kg]
Z1225	30 [14]
Z1225-D	59 [27]

PREFIXES	DESCRIPTION	SINGLE	DOUBLE
Z1225*	Dura-Coated System with Universal Plate	838.00	-
Z1225-D	Back-to-Back System	-	1,168.00
SUFFIXES		ADD	
-BL	Bi-Level Cooler Support	388.00	775.00
-CB	Carrier Bank (Per Each)	POA	POA
BEST SELLERS		LIST PRICE	
Z1225-BL-UNIV		1,226.00	
Z1225-UNIV		838.00	

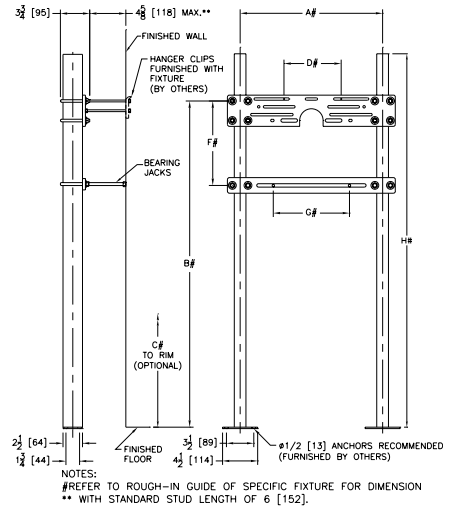

Z1225 (Single)

Z1229 PLATE AND EXPOSED ARM – HEAVY SINKS



ENGINEERING SPECIFICATION

Zurn Z1229 heavy sink support system comes complete with Dura-Coated rectangular steel uprights with welded feet, adjustable top support plate, acid resistant epoxy coated exposed arms mounted on cast iron adjustable header, and mounting fasteners.

NOTES

Dimensional data for letter dimensions depends on fixture type and manufacturer. See Zurn Carrier/Fixture Rough-In information at www.zurn.com for specific rough-in dimensions.

Product Number	Approximate Weight lb [kg]
Z1229	48 [22]

PREFIXES	DESCRIPTION	LIST PRICE
Z1229*	Dura-Coated System with A.R.C. Exposed Arms	2,688.00
SUFFIXES		ADD
-WS	Wall Support Valve Plate (Specify Valve Name and Number)	151.00
-1	Longer Sink - Ea. 1' over 3' (Specify Length per Foot)	897.00

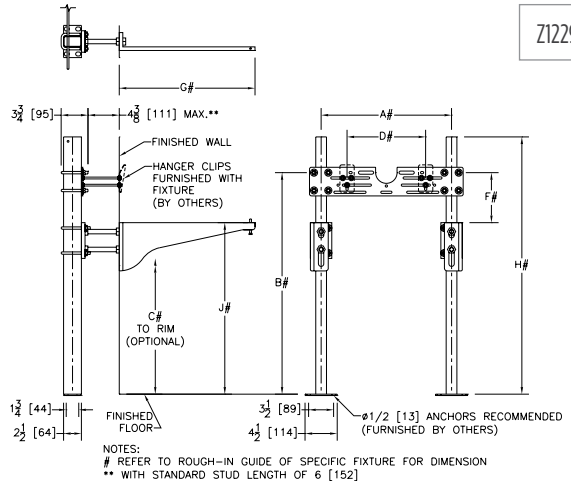

Z1229 (Single)

*Regularly furnished unless otherwise specified.

For additional product information, please visit www.zurn.com

Items designated as Best Sellers are most specified and are generally in stock for shipment.

Ⓢ This symbol denotes a product that is engineered to reduce installation and rework time.

For Additional System Tools See "Z1200 Carrier Tools and Accessories" on page 214